

Shrink Wrappers-Tunnel

Shrink wrapper of bags with flaps.
Model ZEA-90 PS.

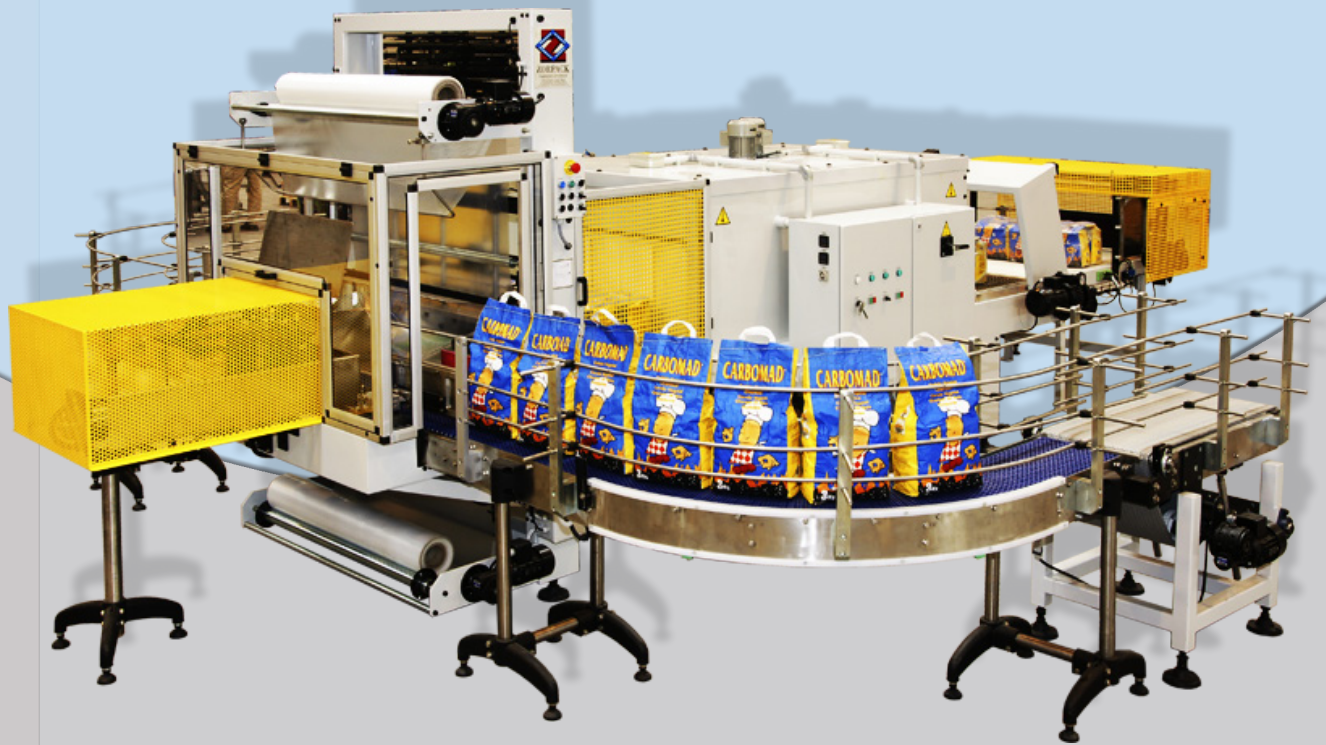

OPERATION

The product is placed on the machine's input tray at 90°. The machine has a braking, decompression and pushing cylinder assembly that separates the product in the requested formats. It has been specially designed to process bags with a top flap, it features various pneumatic systems that fold the flaps according to the customer's specifications: all in the same direction, longitudinally or transversally, three leftwards and the last rightwards.

TECHNICAL FEATURES

Shrink wraps with polyethylene film.

Flap folding system for different products.

Electronic temperature control in the shrink wrap and welding tunnel.

Manual controls and fully automatic operation.

Top quality materials: OMRON automation system, FESTO pneumatic system, TELEMECANIQUE electrical devices.

PRODUCTS AND MARKET SECTORS

Designed to handle gusseted bags with different products: animal feed, carbon, kitty litter.



Shrink Wrappers-Tunnel

Shrink wrapper of bags with flaps.
Model ZEA-90 PS.

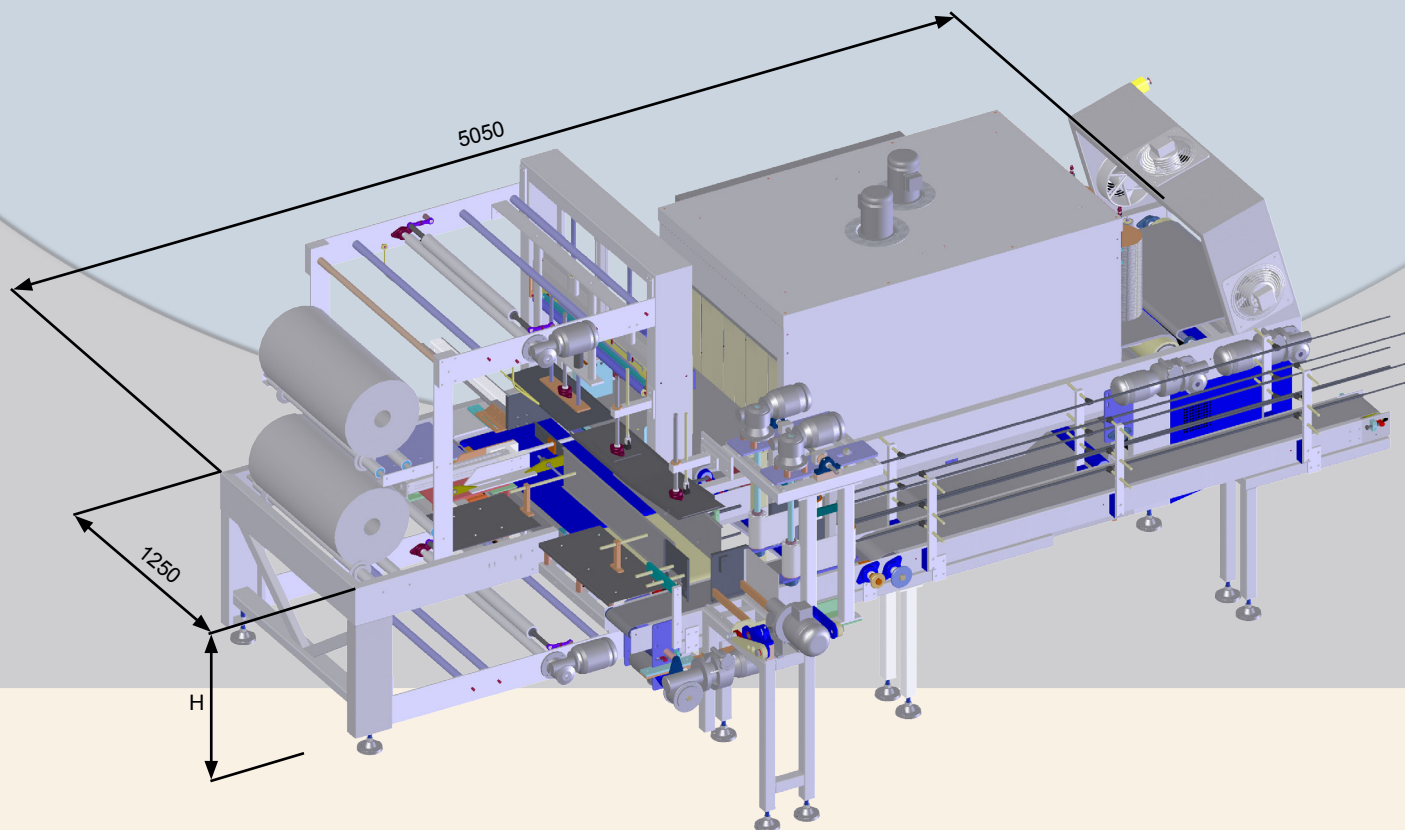

Voltage	220v or 380v
Power	32 Kw
Weight	1500 Kg
Air consumption	100 l/min
Air pressure	6 atm.
Film thickness	50-100 microns
Production	12-14 p/min according to product-bundle size



ZORPACK

Polígono Industrial Comarca-2, calle B, N° 20
31191 Ezquiroz (Navarra)
Tel.: +34 948 303 005
Fax: +34 948 302 644
E-mail: zorpack@zorpack.com
www.zorpack.com